



Anti water hammer combination air valve

Mod. FOX 3F - AS

The CSA air valve Mod. FOX 3F AS will ensure the proper operation of the pipeline network allowing the release of air pockets during working conditions, the entrance of large volumes of air during draining operations and pipeline bursts and the air discharge with controlled speed, to prevent water hammer.



Technical features and benefits

- Single chamber full bore body in ductile cast iron, PN 40 bar rated, provided with internal ribs for consistent and accurate guiding of the mobile block.
- Drainage valve produced by CSA, for chamber control and pressure relief during maintenance.
- Mobile block composed of a cylindrical float and upper disk in solid polypropylene, joined together by the CSA air release system in AISI 316 (pat. Pending). The solid cylindrical floats, obtained by CNC machining only, avoid deformations and ensure a great sliding precision inside the body processed ribs and a perfectly vertical thrust.
- Nozzle and gasket holder, part of CSA air release system, entirely made in AISI 316.
- Maintenance can be easily performed from the top, without removing the air valve from the pipe.
- Anti water hammer system (also called AS function), never in contact with water, obtained by a spring and shaft in stainless steel, disk with adjustable sonic nozzles for air flow control.
- Cover in ductile and screen in stainless steel as a standard execution, to prevent the entrance of insects, with optional outlet for submerged applications.

Applications

- Main transmission lines.
- Water distribution networks.
- Irrigation systems.
- In general this model is used near pumps, on changes in slope ascending, and at the high points of the pipeline subjected to water hammer.

Operating principle

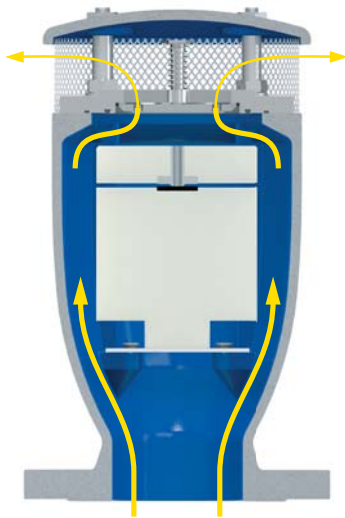

Controlled air discharge

During the pipe filling it is necessary to avoid rapid closures, responsible of water hammer effects. The FOX 3F AS, thanks to the anti-shock feature, will control the air outflow thus reducing the velocity of the approaching water column. The risk of overpressure will therefore be minimized.

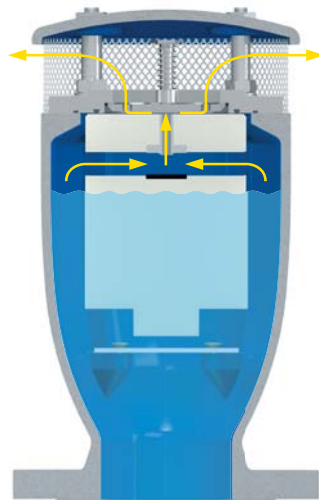

Air release during working conditions

During operation the air produced by the pipeline is accumulated in the upper part of the air valve. Little by little it is compressed and the pressure arrives to water pressure, therefore its volume increases pushing the water level downwards allowing the air release through the nozzle.



Entrance of large volumes of air

During pipeline draining, or pipe bursts, it is necessary to bring in as much air as the quantity of outflowing water to avoid negative pressure and serious damages of the pipeline, and to the entire system.

Optional



■ **Vacuum breaker version Mod. FOX 2F AS**, to allow the entrance of large volumes of air and the controlled outflow only. This model is normally recommended in changes in slope ascending, long ascending segments, dry fire systems.



■ **Version for submerged applications, SUB series**, available both for FOX 3F AS and 2F AS Models, with elbow for air conveyance. The design sprang from the necessity of having an air valve performing also in case of flood, without the risk of contaminated water entering the pipeline. Another benefit of SUB is the possibility of conveying spurts coming from the closure away from the air valve.



■ The counteracting spring force as well as the sonic nozzles, both responsible of the proper operation of the AS device, can be modified on request according to the project conditions and the transient analysis.

Technical data

Air valve selection chart

Air valve size as a function of pipeline internal diameter and fluid flow velocity expressed in m/s.

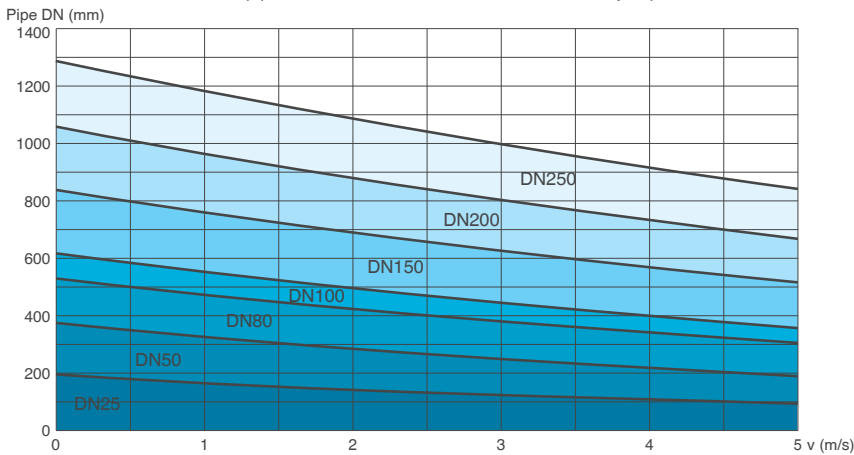

Air flow performance charts

AIR ENTRANCE DURING PIPE DRAINING

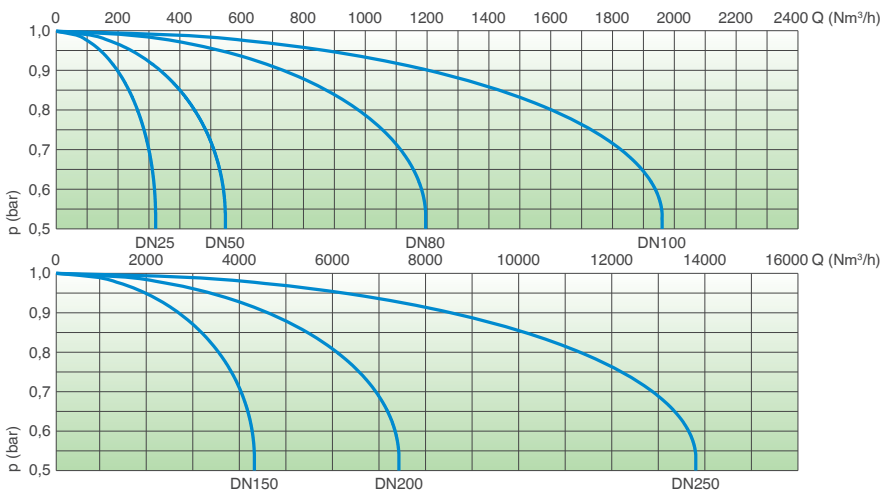

AIR ENTRANCE DURING PIPE DRAINING

AIR RELEASE DURING WORKING CONDITIONS

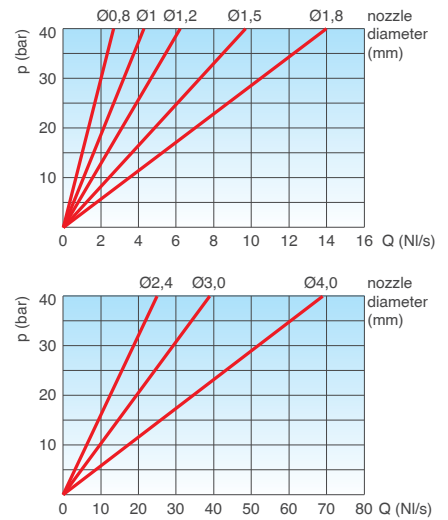

The air flow charts were created in Kg/s from laboratory tests and numerical analysis, then converted using a safety factor.

AS system orifices specification

Details of CSA anti-slam system air regulation adjustable orifices, with minimum and maximum outflow section.

	orifices	min. area (mm ²)	max. area (mm ²)
DN 25	Ø3X2+M3X2	14	28
DN 50	Ø4X2+M4X2	25	50
DN 80	Ø6X2+M6X2	56	113
DN 100	Ø7X2+M6X2	77	133
DN 150	Ø10X3+M6X3	235	320
DN 200	Ø14X3+M8X3	461	612
DN 250	Ø18X3+M12X3	763	1102

Working conditions

Pressure ratings:

- PN 16: 0.09 - 16 bar
- PN 35: 0.15 - 35 bar
- PN 40: 0.15 - 40 bar.

Temperature max. 60°C.

Coating FBE - RAL 5005.

Standard

Designed in compliance with:

- EN-1074/4
- AS 4956
- AS 4020
- AWWA C-512.

Connections

Threaded: ■ BSP - F

- NPT on request.

Flanges: ■ AS 4087 PN 16

- AS 4087 PN 35
- ANSI on request.

Weights and dimensions

CONNECTION inch/mm	A mm	B mm	C mm		D mm	Weight Kg
Threaded 1"	117	240	-	-	CH 45	4,0
Threaded 2"	141	295	-	-	CH 70	7,5
Flanged 50	141	305	165	-	-	9,5
Flanged 80	172	315	210	205	-	13,8
Flanged 100	206	370	235	220	-	21,7
Flanged 150	285	515	305	285	-	44,5
Flanged 200	380	625	375	340	-	85,0
Flanged 250	440	785	450	-	-	134,0

All values are approximate, consult CSA service for more details.

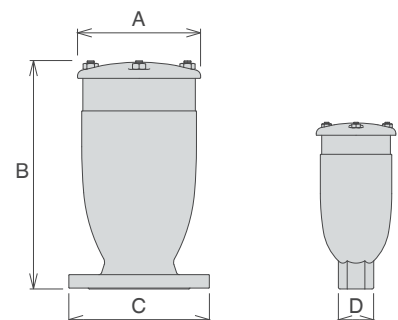

Technical details

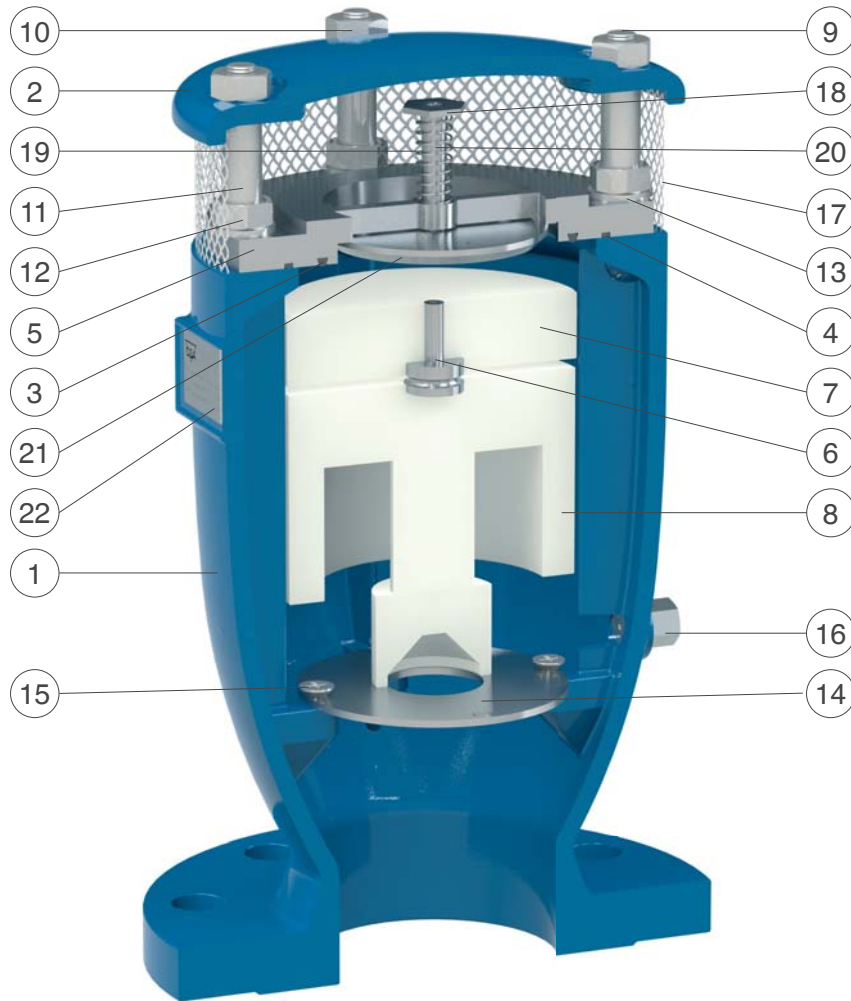

SUB version kit in plastic, or stainless steel on request.

N.	Component	Standard material	Optional
1	Body	ductile cast iron GJS 500-7 or GJS 450-10	
2	Cap	ductile cast iron GJS 500-7 or GJS 450-10	
3	O-ring	NBR	EPDM/Viton/silicone
4	O-ring	NBR	EPDM/Viton/silicone
5	Seat	stainless steel AISI 316	
6	Nozzle subset	stainless steel AISI 316	
7	Upper flat	polypropylene	
8	Float	polypropylene	
9	Studs	stainless steel AISI 304	stainless steel AISI 316
10	Nuts	stainless steel AISI 304	stainless steel AISI 316
11	Spacers	stainless steel AISI 304	stainless steel AISI 316
12	Nuts	stainless steel AISI 304	stainless steel AISI 316
13	Washers	stainless steel AISI 304	stainless steel AISI 316
14	Deflector	stainless steel AISI 316	
15	Screws	stainless steel AISI 316	
16	Drain valve	stainless steel AISI 316	
17	Screen	stainless steel AISI 304	
18	Spring guide nut (from DN 100)	stainless steel AISI 303	stainless steel AISI 316
19	Spring	stainless steel AISI 302	
20	AS shaft	stainless steel AISI 303	stainless steel AISI 316
21	AS flat	stainless steel AISI 304	stainless steel AISI 316
22	Tag	stainless steel AISI 304	

The list of materials and components is subject to changes without notice.